

BAK-Q80, BAK-Q60

OPERATION & MAINTENANCE
MANUAL

FUEL FILLER SECURITY
TYPE **BAK-Q80, BAK-Q60**

WARSAW, APRIL 2011

4.2. Plug cover

Plug cover protects the plug locking mechanism from dirt, making the plug more comfortable to use and prolonging its life. The plug needs to be covered between each refueling operation.



4.3. Anti-theft strainer

The anti-theft strainer is a pipe with perforated walls and bottom. The shape of the bottom and size of holes have been fitted so as not obstruct the filling operation while protecting against theft.

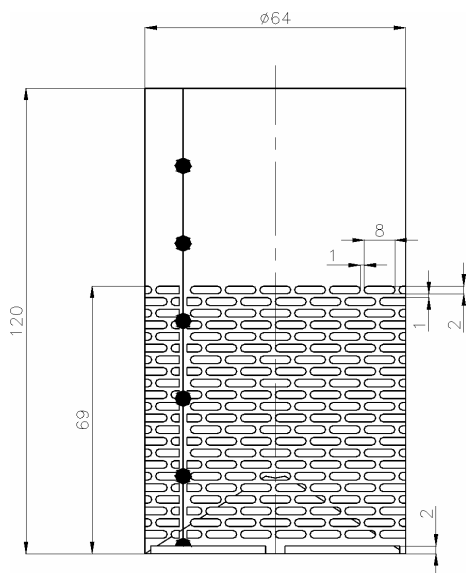

Pic.3. BAK-Q80 anti-theft strainer

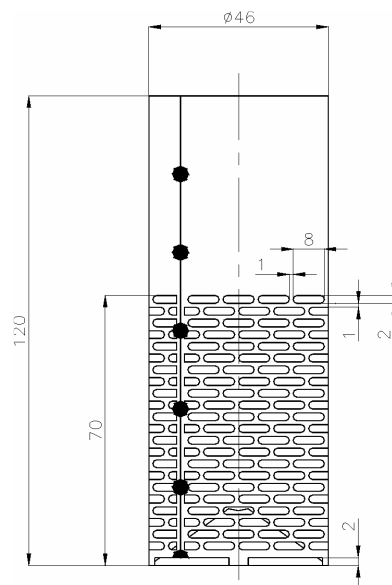

Pic.4. BAK-Q60 anti-theft strainer

5. PICTURE INDEX.

- Pic.1. BAK-Q80, BAK-Q60 – dimensions.
- Pic.2. Float seal.
- Pic.3 BAK-Q80 anti-theft strainer.
- Pic.4 BAK-Q60 anti-theft strainer.

CONTENTS

1. TECHNICAL DESCRIPTION	2
1.1. DESIGNATED USE	2
1.2. TECHNICAL SPECIFICATION.....	3
1.3. STRUCTURE & OPERATION.....	3
2. ASSEMBLY AND USAGE.....	3
2.1. MECHANICAL SYSTEM.....	3
2.2. ELECTRICAL SYSTEM.....	4
2.3. SAFETY MEASURES.....	6
2.4. OPERATION MANUAL.....	6
3. STORAGE AND TRANSPORTATION.....	7
3.1. STORAGE.....	7
3.2. TRANSPORTATION.....	7
4. ACCESSORIES.....	7
4.1. FLOAT SEAL.....	7
4.2. PLUG COVER.....	8
4.3. ANTI-THEFT STRAINER	8
5. PICTURE INDEX.....	8

THE MANUFACTURER RESERVES THE RIGHT TO INTRODUCE ALTERATIONS (WHICH DO NOT CAUSE DETERIORATION OF USAGE AND MEASURING PARAMETERS IN THE DEVICE) WITHOUT UPDATING THE CONTENTS OF OPERATION & MAINTENANCE MANUAL.

1. TECHNICAL DESCRIPTION.

1.1. Designated use.

The plug module BAK-Q80, BAK-Q60 controls and monitors fuel filler access on trucks, machinery, construction equipment. As an option, it can be equipped with additional event signaling devices for the driver and an anti-burglary strainer.

The system is composed of three modules:

- “BAK-Q80 or BAK-Q60 PLUG MODULE”
- “CABIN SIGNALING DEVICE MODULE”
- “ANTI-THEFT STRAINER MODULE”

which can also function as separate devices. “PLUG MODULE” and/or “CABIN SIGNALING DEVICE MODULE” is connected to the monitoring system. “CABIN SIGNALING DEVICE MODULE” has a preset number of elements for signaling events to the driver.

The system is completed with a FLOAT SEAL which prevents unscrewing the float and disconnecting the return hose.

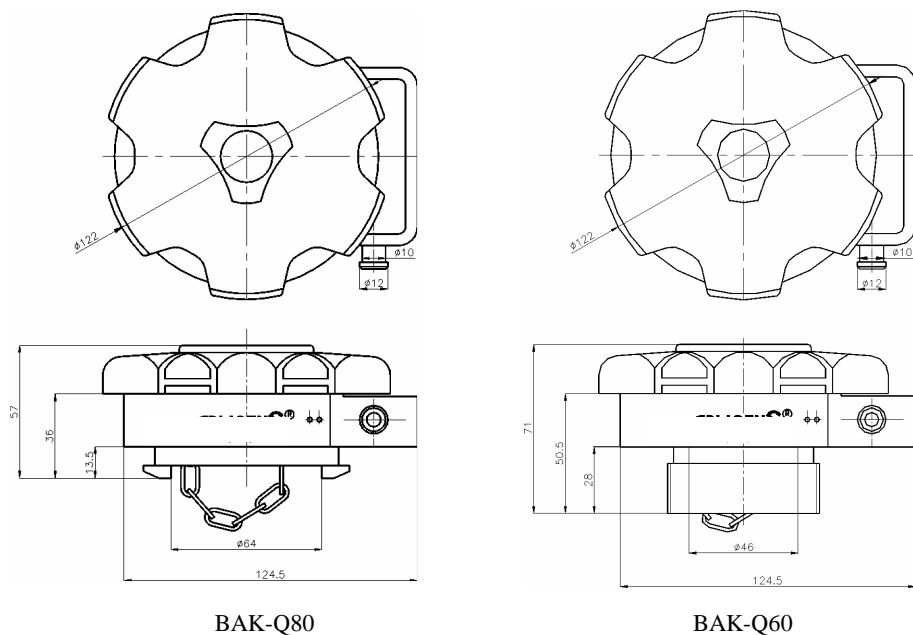

BAK-Q80

BAK-Q60

Pic.1. BAK-Q80, BAK-Q60 – dimensions.

1.2. BAK-Q80 & BAK-Q60 technical specification.

Power 16 ÷ 32V DC, max 35V

Current draw 35mA

Working temperature -25...+80°C

OC type signal parameters $U_{max} = V$ of power; $I_{max} = 20$ mA DC

2.4.3. Maintenance

If the system is mounted properly, it does not require any maintenance operation for a period of 3 years. After that, check the insulation of PLUG MODULE cable.

In order to prevent the plug or the locking mechanism from being damaged mechanically, keep the plug clean and remember to close the cover of the locking mechanism. Do not lubricate or pour diesel fuel on it.

3. STORAGE AND TRANSPORTATION.

3.1. Storage.

BAK-Q80 and BAK-Q60 must be stored in their original packaging in a closed area, free from corrosive agents, in temperatures from 0°C to 70°C, with relative humidity no higher than 80%. Ensure anti-shock and anti-vibration protection.

3.2. Transportation.

Transportation of BAK-Q80 and BAK-Q60 should be performed with a covered-top means of transport. The packaging should be protected against movement.

4. ACCESSORIES

4.1. Float seal

Prevents unscrewing the original float – sucker and stealing fuel. If mounted properly, it prevents removing the return hose of the fuel system and stealing the fuel with the „drop by drop” method. The seal is mounted onto 8 removable sealable rivets.

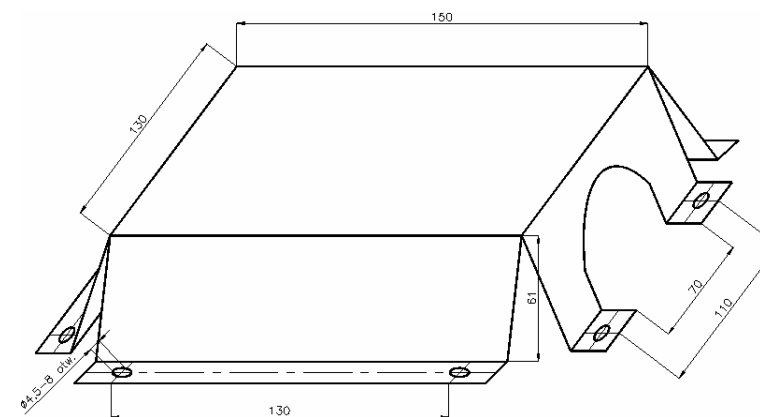

Pic.2. Float seal

2.3. Safety measures.

All operation (inspection, checks) must be performed after studying carefully the Operation & Maintenance Manual.

Before performing any connection operation, disconnect electrical power from the device.

2.4. Operation Manual

After having been mounted, the system does not require operation, except resetting the ALARM and closing the plug. To do this, the driver should turn off the ignition lock.

2.4.1. Normal operation

Once power has been connected, the system is ready to work.

When the plug is closed:

- PLUG MODULE output indicates high status, equal to power voltage
- CABIN SIGNALING DEVICE MODULE output 1 indicates high status, equal to power voltage
- CABIN SIGNALING DEVICE MODULE output 2 indicates low status

When the plug is open:

- PLUG MODULE output indicates low status
- CABIN SIGNALING DEVICE MODULE output 1 indicates low status
- CABIN SIGNALING DEVICE MODULE output 2 indicates high status, equal to power voltage

When the PLUG MODULE cable has been cut (sabotage):

- CABIN SIGNALING DEVICE MODULE output 1 indicates low status
- CABIN SIGNALING DEVICE MODULE output 2 indicates high status, equal to power voltage

A beeping signal in the cabin.

Opening the plug or cutting the cable from BAK-Q80 or BAK-Q60 when the ignition lock is turned on will trigger a beeping sound and activate a LED diode in the cabin. After closing the plug, CABIN SIGNALING DEVICE MODULE enters the ALARM MEMORY mode, the LED diode flashes and there is no beeping sound. After the key in the ignition has been turned, the device enters basic mode.

SILENT OPENING – the ignition is left on, there is no beeping sound while refueling.

2.4.2. Programming.

The user cannot program new fuel filler plugs. If necessary, please contact the manufacturer or authorized service.

1.3. Structure and operation

BAK-Q80 and BAK-Q60 both work by controlling the presence of the transponder, situated in the fuel plug, over the “PLUG MODULE” mounted in the tank’s filler. The system interprets unscrewing the plug as a change in output state or sabotage, cutting the cable through loss of signal on communication cord. The cord can be connected to the monitoring system and/or “CABIN SIGNALING DEVICE MODULE”.

The “CABIN SIGNALING DEVICE MODULE” notifies of the plug having been unscrewed (the cable having been cut - sabotage) with a LED diode and a beeper in the driver’s cabin. It can be connected to the monitoring system that records all events. Optionally, “CABIN SIGNALING DEVICE MODULE” operates with SILENT OPENING feature (unscrewing the plug is not signaled with a beep in the cabin) and ALERT MEMORY feature (information of unscrewing the plug is stored when the driver is not present in the cabin).

“CABIN SIGNALING DEVICE MODULE” generates two types of signals for unscrewing the plug: normal opening NO and normal connection NC.

All signals are generated in OC type (opened collector).

“ANTI-THEFT STRAINER MODULE” is an integral part of “PLUG MODULE” and is mounted during production.

2. ASSEMBLY AND USAGE.

2.1. Mechanical system

- Unscrew the original plug from the fuel filler.
- Degrease the tank fuel filler and the flange of PLUG MODULE using a cloth supplied in the assembly kit.
- Put silicone onto the fuel filler and the flange of PLUG MODULE
- Put a seal onto the flange of PLUG MODULE
- Mount PLUG MODULE with seal onto the fuel filler, turn the screw to the right until it is tightly screwed. It is recommended to use a flange in order to prevent the cable from sticking outside the vehicle.
- Drill a Ø4 mm bore carefully through the mounting wholes in the filler.
- Put the mounting sleeve onto the removable rivet and place it in the riveter. Rivet both wholes.
- The cord must be protected with PROTECTIVE PIPE, which needs to be tightened on the flange of PLUG MODULE housing. Use a tie-rib. Guide the cable to the driver’s cabin in such a way as to minimize all possible thermal and mechanical damage resulting from day-to-day use of the vehicle.
- Thread the seal line with bead through the seal wholes, tie it around the PROTECTIVE PIPE. Seal it.
- Put silicone into the mounting wholes and push the rubber caps inside.
- Cut away the protruding cap parts.
- Screw the plug on the PLUG MODULE, unscrew and screw the plug again a few times in order to check the quality of PLUG MODULE assembly onto the fuel tank.
- Put the plug cover on the PLUG MODULE and tighten the string. Ensure the plug cover sticks to the fuel filler all the way. Secure the loose string.

OPERATION MODULE assembly.

- Screw the supplied plug tightly on PLUG MODULE housing. Unscrew and screw the plug again a few times in order to check the quality of PLUG MODULE assembly onto the fuel tank and check the tightness of the safety screws.
- The CABIN SIGNALING DEVICE MODULE should be mounted under the dashboard in the driver's cabin.
- Choose a proper location for the device to be mounted, minimizing the risk of any possible damage resulting from day-to-day use of the vehicle and taking into consideration all the signals necessary to mount the device properly.
- The beeper must be mounted close to the top of the dashboard.
- Mount the beeper by hitching its cables to another group of electrical cables of the vehicle, using assembly clips.
- The LED signal diode must be mounted in a visible place on the dashboard of the vehicle by drilling a $\phi 8$ mm hole.
- Mount the LED diode in the black plastic cover.
- Push the diode cover firmly into the drilled hole on the top side of the dashboard.

2.2. Electrical system

2.2.1. Cable description

CABIN SIGNALING DEVICE MODULE – colors:

- Blue - ground
- Red - +24V
- Black - + after key
- White - input (signal from BAK-Q80 or BAK-Q60)
- Green - input (signal from BAK-Q80 or BAK-Q60)
- Yellow - output 1 OC type (high status when BAK-Q80 or BAKQ60 closed)
- Brown - output 2 OC type (low status when BAK-Q80 or BAKQ60 closed)

PLUG MODULE – colors:

- Black - ground
- Red - +24V
- Grey – OC type output

2.2.2. Cable connection

PLUG MODULE connection to external systems

Because of universal nature of the signals, the Installer should adapt the connection to external system requirements. We recommend connecting the signal from PLUG MODULE to the 0/1 input that indicates each status change, or to „pulse” input which responds to presence or lack of pulse, thus enabling detection of sabotage – cutting the cable.

Power cable connection

Connect the +24V cable to positive voltage of the battery, connect the 'ground' cable to negative voltage of the battery.

Connecting PLUG MODULE to CABIN SIGNALING DEVICE MODULE

Connect + after key (power output behind the ignition lock) to the „black” cable from CABIN SIGNALING DEVICE MODULE in order to use ALARM MEMORY function fully.

Single-tank set:

Connect the 'grey' cable from PLUG MODULE in a fixed electrical connection to 'green' and 'white' from CABIN SIGNALING DEVICE MODULE

Double-tank set:

Connect the 'grey' cable from the first PLUG MODULE in a fixed electrical connection to 'green' cable from CABIN SIGNALING DEVICE MODULE
Connect the 'grey' cable from the second PLUG MODULE in a fixed electrical connection to 'white' cable from CABIN SIGNALING DEVICE MODULE